



### Applications

- Intermediate bus architectures
- Telecommunications equipment
- LAN/WAN
- Data processing

### Features

- RoHS lead solder exemption compliant
- High efficiency, up to 94%
- High power density - 91W/in<sup>3</sup>
- High current rating - 42A
- Low profile – 12.7mm height
- Input/output isolation: 1500VDC
- Basic insulation
- Start-up into high capacitive load
- Low conducted and radiated EMI
- Output overcurrent protection
- Output overvoltage protection
- Overtemperature protection
- Remote sense
- Remote On/Off (primary referenced), positive or negative logic option
- ±10% output voltage trim adjust
- UL 1950 recognition, CSA 22.2 No. 950-95 certification, TUV IEC950

### Description

The FBC Series of high density bus converters convert a worldwide telecom bus voltage of 36 to 75 VDC to a 12V bus at 42 A. The output is ideal for powering non-isolated, point-of-load converters such as synchronous buck converters used commonly in Intermediate Bus Architectures.

The unit's open-frame, two-board construction provides ideal thermal transfer for maximum reliability. Power devices are mounted on an Insulated Metal Substrate (IMS) base plate with very low thermal impedance. The control PCB is physically isolated from the hotter IMS board, providing lower overall component temperatures for high reliability. The standard feature set includes remote on/off, remote output voltage sensing, positive output trim, and input undervoltage lockout and overtemperature shutdown with hysteresis.

Model Selection						
Model	Input voltage (VDC)	Input current, Max, (ADC)	Output voltage (VDC)	Output rated current I <sub>rated</sub> , (ADC)	Output Ripple/Noise (mV p-p)	Typical Efficiency @ I <sub>rated</sub> , (%)
FBC42ZH	36-75	16	12.0	42	100	92.5
This product is intended for integration into end-use equipment. All the required procedures for CE marking of end-use equipment should be followed.						

 Model numbers highlighted in yellow or shaded are not recommended for new designs.

### Absolute Maximum Ratings

Stresses in excess of the absolute maximum ratings may cause performance degradation, adversely effect long-term reliability, and cause permanent damage to the converter.

Parameter	Conditions/Description	Min	Max	Units
Input voltage	Continuous		75	VDC
	Transient, 100 ms		100	VDC
Operating Temperature	Base Plate Temperature	-40	110	°C
Storage Temperature		-40	125	°C
ON/OFF Control Voltage	Referenced to -Vin		7	VDC

### Environmental and Mechanical Specifications

All specifications apply over specified input voltage, output load, and temperature range, unless otherwise noted.

Parameter	Conditions/Description	Min	Nom	Max	Units
Shock	Halfsine wave, 3 axes	50			g
Sinusoidal Vibration	GR-63-CORE, Section 5.4.2	1			g
Weight			5.2/145		Oz/gm
Water Washing	Standard process		Yes		
MTBF	Per Bellcore TR-NWT-000332		1,000		kHrs

### Isolation Specifications

All specifications apply over specified input voltage, output load, and temperature range, unless otherwise noted.

Parameter	Conditions/Description	Min	Nom	Max	Units
Insulation Safety Rating		Basic			
Isolation Voltage	Input to output, input to base plate	1500			VDC
Isolation Voltage	Output to base plate	1500			VDC
Isolation Resistance		10			MOhm
Isolation Capacitance			1000		pF

### Input Specifications

All specifications apply over specified input voltage, output load, and temperature range, unless otherwise noted.

Parameter	Conditions/Description	Min	Nom	Max	Units
Input Voltage	Continuous	36	48	75	VDC
Turn-On Input Voltage	Ramping Up	33		35	VDC
Turn-Off Input Voltage	Ramping Down	31.5		33.5	VDC
Turn-On Time	To Output Regulation Band 100% Resistive Load			5	ms
Input Reflected Ripple Current	Full Load, 12µH source inductance			60	mA p-p
Inrush Transient	Vin = Vin.max			0.1	A <sup>2</sup> s

**Output Specifications**

All specifications apply over specified input voltage, output load, and temperature range, unless otherwise noted.

Parameter	Conditions/Description	Min	Nom	Max	Units
Output Voltage Setpoint Accuracy	Vin = Vin.nom, Full Load	-2		2	%Vout
Output Current	See selection chart for I <sub>rated</sub>	10		100	%I <sub>rated</sub>
Line Regulation	Vin.min to Vin.max, I <sub>rated</sub>			0.5	%Vout
Load Regulation	Vin = Vin.nom, 10% to 100%I <sub>rated</sub>			1.0	%Vout
Total output voltage regulation	Over all input voltage, load, and temperature conditions	-4		4	%Vout
Remote Sense Headroom				5%	%Vout
Dynamic Regulation	50-75% load step change				
Peak Deviation			250	500	mV
Settling Time	to 1% error band		400	500	μs
Admissible Load Capacitance	I <sub>rated</sub> , resistive load, Nom Vin			5,000	μF
Output Current Limit Threshold**	Vout ≤ 0.97Vout.nom	115		130	%I <sub>rated</sub>
Switching Frequency			400		kHz
Overvoltage Protection, Non Latching	Over all input voltage and load conditions	120		140	%Vout
Trim Range	I <sub>rated</sub> , Vin = Vnom	90		110	%Vout

\*\* Overcurrent protection is non-latching with auto recovery.

**Feature Specifications**

All specifications apply over specified input voltage, output load, and temperature range, unless otherwise noted.

Parameter	Conditions/Description	Min	Nom	Max	Units
Shutdown (ON/OFF)					
Negative Logic	On/Off signal is low – converter is ON				
Converter ON		-0.5		0.8	VDC
Source Current	ON/OFF pin is connected to -Vin			1	mADC
Converter OFF		2.5		7	VDC
Open Circuit Voltage	ON/OFF pin is floating			5	VDC
Positive Logic	On/Off signal is low–converter is OFF				
Converter ON		2.5		7	VDC
Open Circuit Voltage	ON/OFF pin is floating			5	VDC
Converter OFF		-0.5		0.8	VDC
Source Current	ON/OFF pin is connected to -Vin			1	mADC
Overtemperature Protection	Baseplate temperature	120		130	°C

**Characteristic Curves**

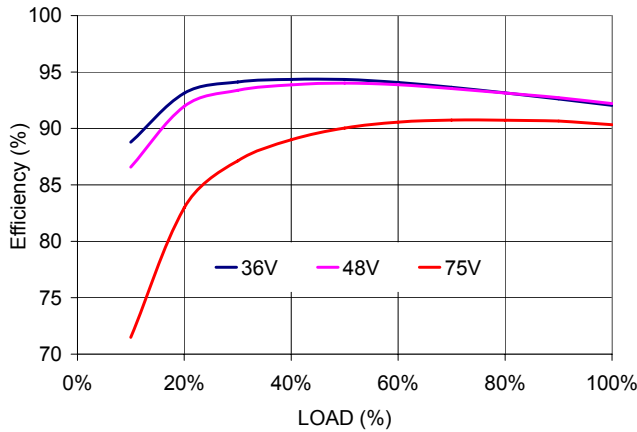

**Figure 1. FBC42ZH Efficiency Vs. Output Load**

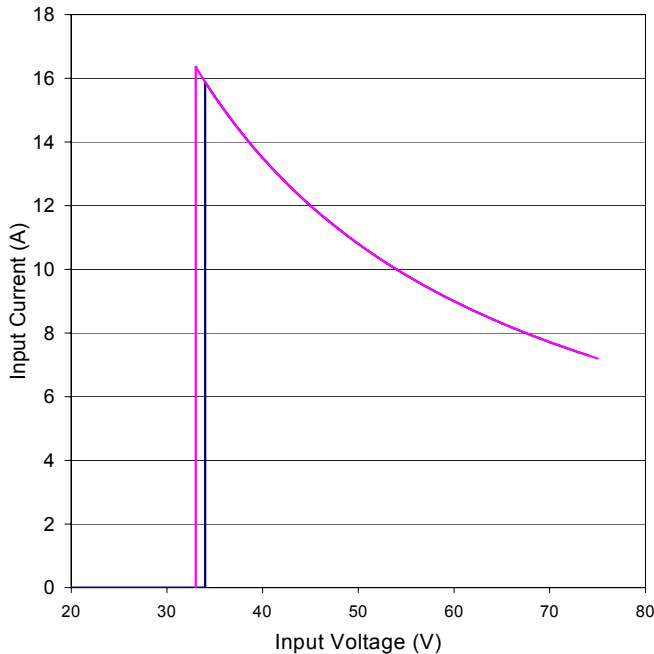

**Figure 2. FBC42ZH Input Characteristic**

**Typical Application**

Figure 3 shows the recommended connections for the FBC Series converter.

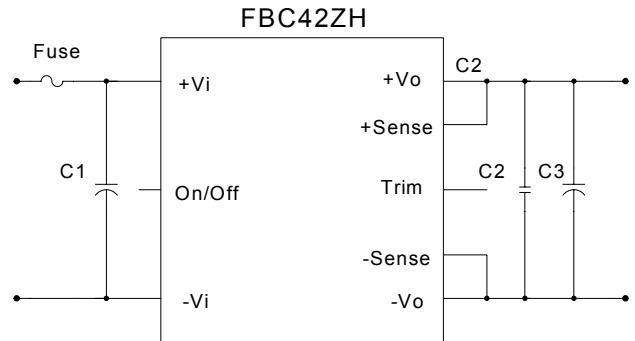

**Figure 3. Typical Application of FBC Series**

The FBC Series converter does not require any external components for proper operation. However, if the distribution of the input voltage to the converter contains significant inductance, the capacitor C1 may be required to enhance performance of the converter. A minimum of a 100µF electrolytic capacitor with the ESR<0.7Ω is recommended for the FBC Series.

Refer to the “Inrush Current Control Application Note” at [www.power-one.com](http://www.power-one.com) for suggestions on how to limit the magnitude of the inrush current.

For output decoupling we recommend to use a 10µF low ESR tantalum (AVX TPSC106M025R0500 is used in our test setup) and a 1µF ceramic capacitors. Note, that the capacitors do not substitute the filtering required by the load.

**Shutdown Feature Description**

The ON/OFF pin in the FBC Series converter functions as a normal soft shutdown. It is referenced to the -Vin pin (see Figure 3). With the positive logic, when the ON/OFF pin is pulled low, the output is turned off and the unit goes into a very low input power mode.

With the negative logic, when the ON/OFF pin is pulled low, the unit is turned on.

An open collector switch is recommended to control the voltage between the ON/OFF pin and the -Vin pin of the converter. The ON/OFF pin is pulled up internally, so no external voltage source is required.

The user should avoid connecting a resistor between the ON/OFF pin and the +Vin pin.

When the ON/OFF pin is used to achieve remote control, the user must take care to insure that the pin reference for the control is really the -Vin pin. The control signal must not be referenced ahead of EMI filtering, or remotely from the unit. Optically coupling the information and locating the optical coupler directly at the module will solve any of these problems.

**Note:**

If the ON/OFF pin is not used, it can be left floating (positive logic), or connected to the -Vin pin (negative logic).

**Output Voltage Trim**

**Industry Standard Positive Trim (suffix -T)**

The -T option units trim up with a resistor from the Trim (#13) pin to the +Sense (#12) pin and trim down with a resistor from the Trim (#13) pin to the -Sense (#11) pin as shown in the Figure 4.

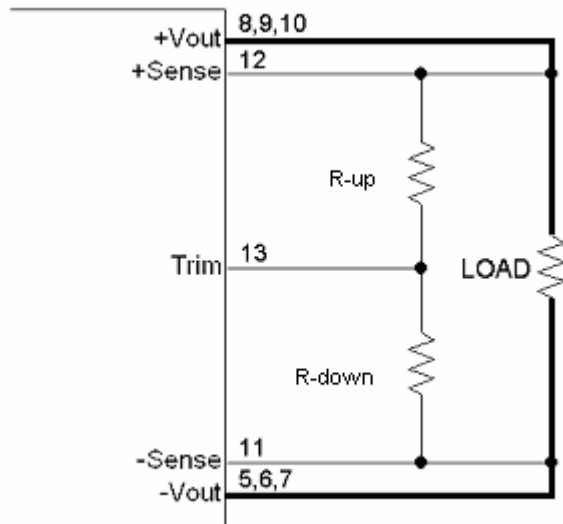

Figure 4. FBC Series Positive Trim Schematic

The equations below determine the trim resistor value required to achieve the desired change in the output voltage.

$$R_{up} = \left( \frac{65.68}{1 - (12/V_{desired})} \right) k\Omega$$

$$R_{down} = \left( \frac{5.97}{(12/V_{desired}) - 1} \right) k\Omega$$

**Notes:**

1. When the output voltage is trimmed up, the output power from the converter must not exceed its maximum rating. The power is determined by measuring the output voltage on the output pins, and multiplying it by the output current.
2. In order to avoid creating apparent load regulation degradation, it is important that the trim resistors are connected directly to the remote sense pins, and not to the load or to traces going to the load.
3. The output voltage increase can be accomplished by either the trim or by the remote sense or by the combination of both. In any case the absolute maximum output voltage increase shall not exceed 10% of the nominal output voltage

**Safety Considerations**

The FBC Series converter features 1500 Volt DC isolation from input to output. The input-to-output resistance is greater than 10MΩ. These converters are provided with Basic insulation between input and output circuits according to all IEC60950 based standards. Nevertheless, if the system using the converter needs to receive safety agency approval, certain rules must be followed in the design of the system. In particular, all of the creepage and clearance requirements of the end-use safety requirements must be observed. These documents include UL60950 - CSA60950-00 and EN60950, although other or additional requirements may be needed for specific applications.

The FBC Series converter has no internal fuse. The external fuse must be provided to protect the system from catastrophic failure as shown in

Refer to Figure 3. The fuse with a rating not greater than 20A is recommended. The user can select a lower rating fuse based upon the highest inrush transient at the maximum input voltage and the maximum input current of the converter, which occurs at the minimum input voltage. Both input traces and the chassis ground trace (if applicable) must be capable of conducting a current of 1.5 times the value of the fuse without opening. The fuse must not be placed in the grounded input line, if any.

In order for the output of the FBC Series converter to be considered as SELV (Safety Extra Low Voltage) or TNV-1, according to all IEC60950 based standards, one of the following requirements must be met in the system design:

- If the voltage source feeding the module is SELV or TNV-2, the output of the converter may be grounded or ungrounded.

- If the voltage source feeding the module is ELV, the output of the converter may be considered SELV only if the output is grounded per the requirements of the standard.
- If the voltage source feeding the module is a Hazardous Voltage Secondary Circuit, the voltage source feeding the module must be provided with at least Basic insulation between the source to the converter and any hazardous voltages. The entire system, including the FBC converter, must pass a dielectric withstand test for Reinforced insulation. Design of this type of systems requires expert engineering and understanding of the overall safety requirements and should be performed by qualified personnel.

**Thermal Considerations**

The FBC Series converter is designed for natural or forced convection cooling. The maximum allowable output current of the converters is determined by meeting the derating criteria for all components used in the converters. For example, the maximum semiconductor junction temperature is not allowed to exceed 125°C to ensure reliable long-term operation of the converters. Contact Power-One for the complete list of the derating criteria.

Figure 5 shows the maximum output current of the FBC converter at different ambient temperatures under both natural and forced (transverse airflow direction, from pin 1 to pin 4) convection.

For example, from Figure 5, the FBC operating at 50°C can deliver up to 24A reliably with 100LFM forced air, while up to 38A reliably with 400LFM forced air.

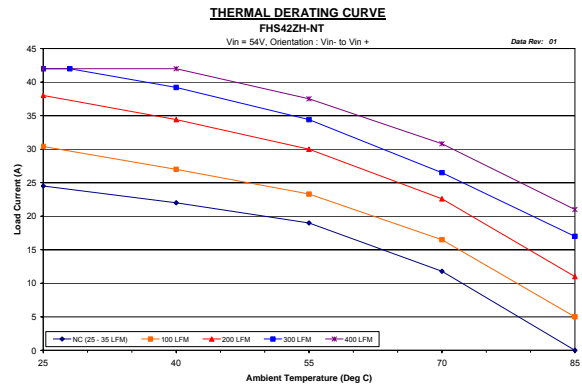

**Figure 5. FBC42ZH Derating Curves**

**Mechanical Drawing**

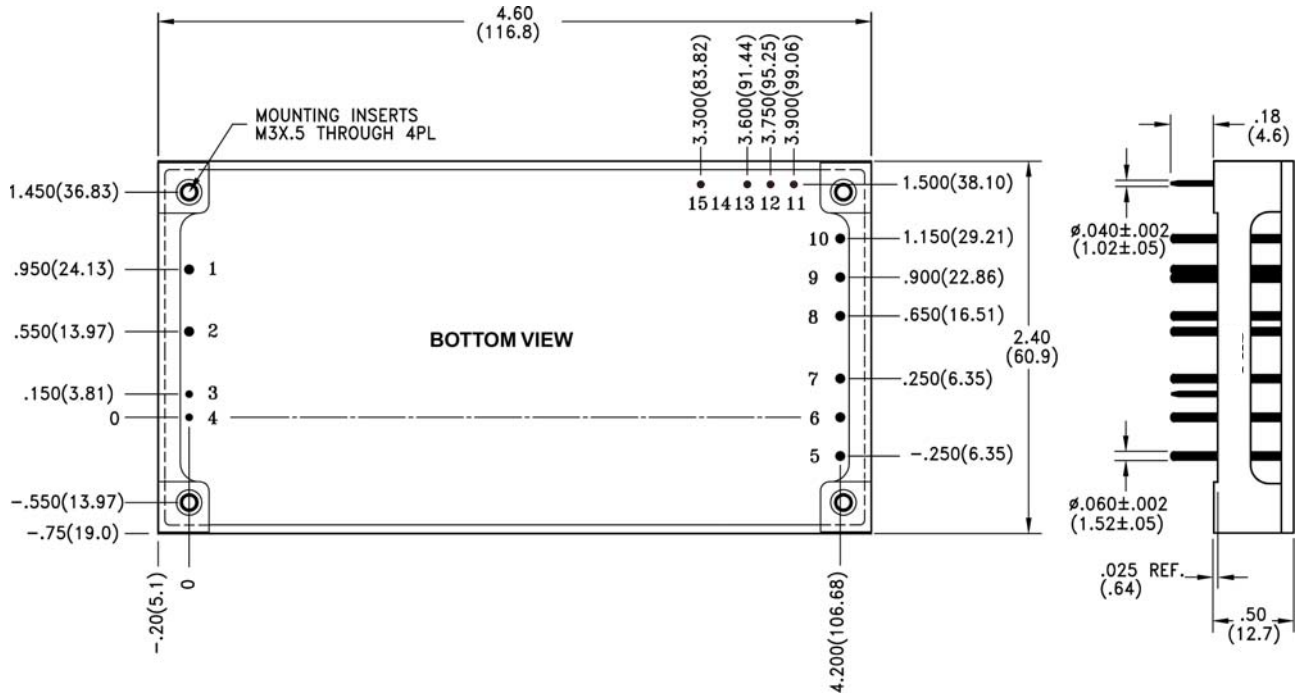

**Mechanical Tolerances**

Inches	Millimeters
X.XX ±0.020	X.X ±0.5
X.XXX ±0.010	X.XX ±0.25

Pin	±0.002	±0.05
-----	--------	-------

Pin	Function
1	-Vin
2	+Vin
3	Sgnd
4	On/off
5, 6, 7	Vout
8, 9, 10	-Vout
11	-Sense
12	+Sense
13	Trim
14	No pin
15	PGOOD

**Ordering Information**

<b>Options</b>	<b>Suffixes to add to part number</b>
Remote ON/OFF	Positive- Standard, no suffix required
	Negative- Add "N" suffix
Trim	Positive - "T" suffix (required - all models)
Pin Length	0.18" - Standard, no suffix required
	0.11" - Add "8" suffix
	0.15" - Add "9" suffix

**Notes**

1. Consult factory for the complete list of available options.

NUCLEAR AND MEDICAL APPLICATIONS - Power-One products are not designed, intended for use in, or authorized for use as critical components in life support systems, equipment used in hazardous environments, or nuclear control systems without the express written consent of the respective divisional president of Power-One, Inc.

TECHNICAL REVISIONS - The appearance of products, including safety agency certifications pictured on labels, may change depending on the date manufactured. Specifications are subject to change without notice.