

Description

The DFA6 Series provides quick power conversion solutions to analog and digital systems and requires few external components. The converters provide plug-and-play versatility. The series features an input range of 3:1. The output is electrically isolated, thereby allowing the output to be configured for positive or negative output voltage. The DFA6 provides compact system power in less than 2.3 square inches (14.8 cm²).

The DFA6 Series' ultra-wide input and no load input current (7mA) makes it well suited for battery operation in commercial and industrial applications. Full overload protection is provided by pulse-by-pulse current limiting.

Features

- RoHS lead-solder-exemption compliant
- Up to 6 watts output power
- Overcurrent protection
- Efficiency to 83%
- Low input-to-output capacitance
- 700 V isolation, input-to-output
- Ultra-wide input range (3:1)



Selection Chart				
Model	Input Range VDC (4)		Output VDC	Output mA
	Min	Max		
DFA6U12S5	9	27	5	1000
DFA6U12S12	9	27	12	500
DFA6U12S15	9	27	15	400
DFA6U48S5	20	60	5	1000
DFA6U48S12	20	60	12	500
DFA6U48S15	20	60	15	400

Model numbers highlighted in yellow or shaded are not recommended for new designs.

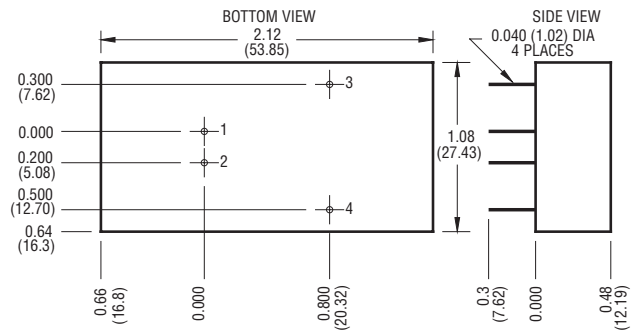

Mechanical tolerances unless otherwise noted:

- X.XX dimensions: ±0.040 inches
- X.XXX dimensions: ±0.010 inches

General Specifications (1)			
All Models			Units
Isolation			
Isolation Voltage	MIN	700	VDC
Input to Output 10µA Leakage			
Input to Output Capacitance	TYP	400	pF
Environmental			
Case Operating Range, Tc	MIN	-40	°C
	MAX	85	
Storage Range	MIN	-55	°C
	MAX	105	
Thermal Impedance (2)	TYP	20	°C/Watt
General			
MTBF (Calculated)	TYP	800,000	HRS
Unit Weight	TYP	1.0 / 28	oz / gm
Chassis Mounting Kits	CM2A1		

Pin	Function
1	+INPUT
2	-INPUT
3	+OUT
4	-OUT

NOTES

- (1) All parameters measured at Tc=25 °C, nominal input voltage and full rated load unless otherwise noted.
- (2) The case thermal impedance is specified as the case temperature rise over ambient per package dissipated.

Input Parameters (1)										
Model		DFA6U12S5	DFA6U12S12	DFA6U12S15	DFA6U48S5	DFA6U48S12	DFA6U48S15	Units		
Voltage Range	MIN	9			20			VDC		
	MAX	27			60					
Reflected Ripple (2)	TYP	1.8			0.85			A _{PP} A _{rms}		
	TYP	0.93			0.44					
Input Current	Full Load	TYP	507	600	130	154	mA			
	No Load	TYP	6	12	5	6				
Efficiency	TYP	82	83	80	82		%			
Switching Frequency	TYP	125						kHz		
Maximum Input Overvoltage	MAX							VDC		
									100ms Maximum	34
									12V Models	72
48V Models										
Turn-on Time, 1% Output Error	TYP	6						ms		

Output Parameters (1)								
Model		DFA6U12S5	DFA6U48S5	DFA6U12S12	DFA6U48S12	DFA6U12S15	DFA6U48S15	Units
Output Voltage		5		12		15		VDC
Output Voltage Accuracy	MIN	4.95		11.90		14.90		VDC
	TYP	5.00		12.00		15.00		
	MAX	5.05		12.10		15.10		
Rated Load Range	MIN	0.0		0.0		0.0		A
	MAX	1.0		0.5		0.4		
Load Regulation 25% - 100% of Rated Load	TYP	0.1		0.2		0.2		%
	MAX	0.3		0.4		0.4		
Line Regulation Vin = Min to Max VDC	TYP	0.02		0.2		0.2		%
	MAX	0.2		0.8		0.8		
Short Term Stability (3)	TYP	< 0.05						%/24Hrs
Input Ripple Rejection (4)	TYP	> 40						dB
Noise, Peak - Peak (2)	TYP	50						mV _{PP}
	TYP	8						mV _{rms}
Temperature Coefficient	TYP	50						ppm/°C
	MAX	150						
Short Circuit Protection +OUT to -OUT		Continuous, Current Limit Protection						

NOTES

- (1) All parameters measured at Tc=25 °C, nominal input voltage and full rated load unless otherwise noted.
- (2) Noise measurement bandwidth is 0-20 MHz for peak-peak measurements, 10 kHz to 1 MHz for RMS measurements. Output noise is measured with a 1 µf / 35 V Tantalum capacitor, 1 inch from the output pins to simulate standard PCB decoupling capacitance. Reflected Ripple is measured with the appropriate input capacitor, and into a 10 µH source impedance. See application notes for input capacitor requirements.
- (3) Short term stability is specified after a 30-minute warmup at full load, constant line and recording the drift over a 24-hour period.
- (4) The input ripple rejection is specified for DC to 120 Hz ripple with a modulation amplitude of 1% of Vin.

DFA6 SERIES APPLICATION NOTES:

External Capacitance Requirements

No external capacitance is required for operation of the DFA6 Series. To meet the reflected ripple requirements of the converter, an input impedance of less than 0.35 ohms from DC to 250 kHz is required.

If a capacitive input source is farther than 1" from the converter, an additional capacitor may be required at the input pins for proper operation. External output capacitance is not required for operation, however it is recommended that 1 μ F to 10 μ F of tantalum and 0.001 to 0.1 μ F ceramic capacitance be selected for reduced system noise. Additional output capacitance may be added for increased filtering, but should not exceed 400 μ F.

Negative Outputs

A negative output voltage may be obtained by connecting the +OUT to circuit ground and connecting -OUT as the negative output.

Temperature Derating

The DFA Single output series can operate up to 85°C case temperature without derating. Case temperature may be roughly calculated from ambient by knowing that the 6 Watt DFA Singles case temperature rise is approximately 20°C per Watt dissipated.

An example: If a 48 volt input converter was delivering 4 Watts, at 48 volts input what ambient could it expect to run with no moving air and no extra heat sinking?

Efficiency for a DFA Single is approximately 78%. This leads to an input power of about 5 Watts. Therefore the case dissipation is 5 Watts (input power) minus 4 Watts (output power) or 1 Watt. The case temperature rise would be 1 Watt x 20°C/W = 20°C. This number is subtracted from the maximum case temperature of 85°C to get: 65°C.

This is an approximation to the maximum ambient temperature. Additional heat sinks and air flow can allow for extended ambient operation as long the max case temp is not exceeded.

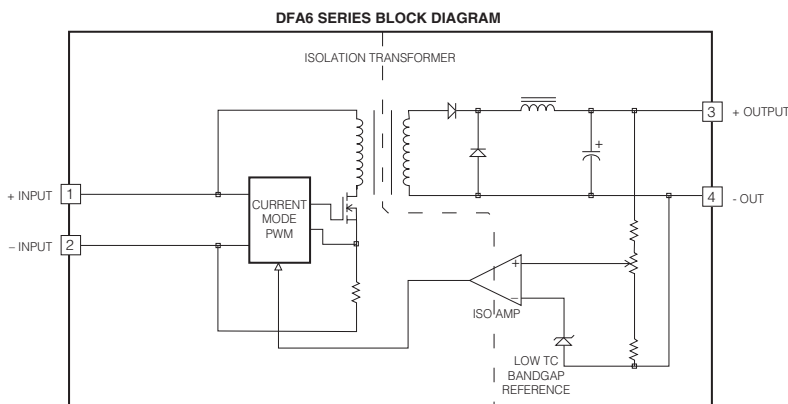

Typical Performance: (Tc=25°C, Vin=Nom VDC, Rated Load)

Data for 12 Volt Input Models

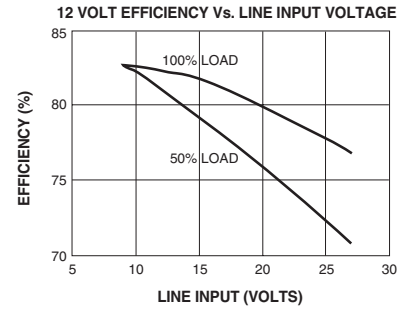
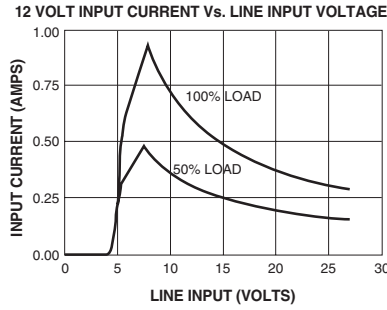
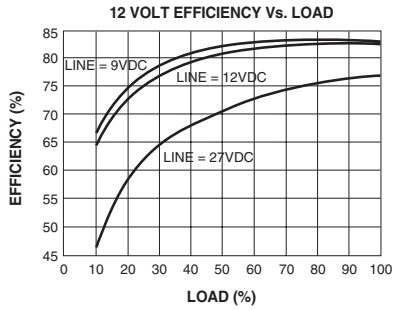

Data for 48 Volt Input Models

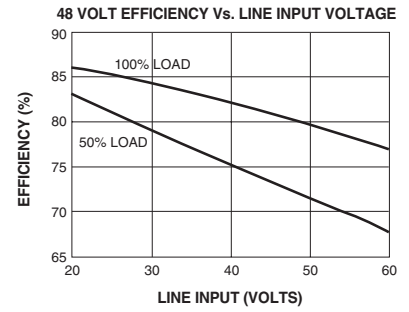
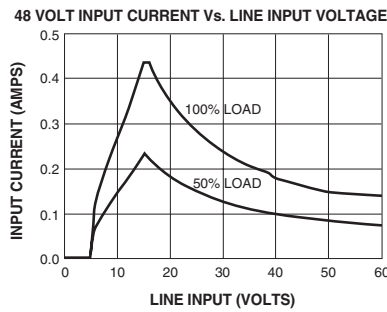
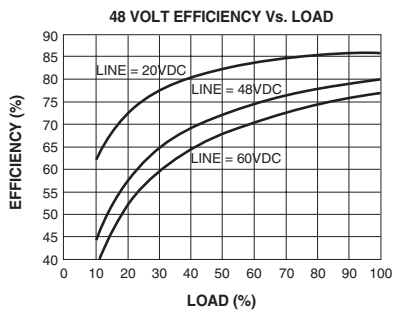

NUCLEAR AND MEDICAL APPLICATIONS - Power-One products are not designed, intended for use in, or authorized for use as critical components in life support systems, equipment used in hazardous environments, or nuclear control systems without the express written consent of the respective divisional president of Power-One, Inc.

TECHNICAL REVISIONS - The appearance of products, including safety agency certifications pictured on labels, may change depending on the date manufactured. Specifications are subject to change without notice.